

Канатный электротельфер Т02 Стационарный (подвесной) на пальцах, полиспаст 2/1

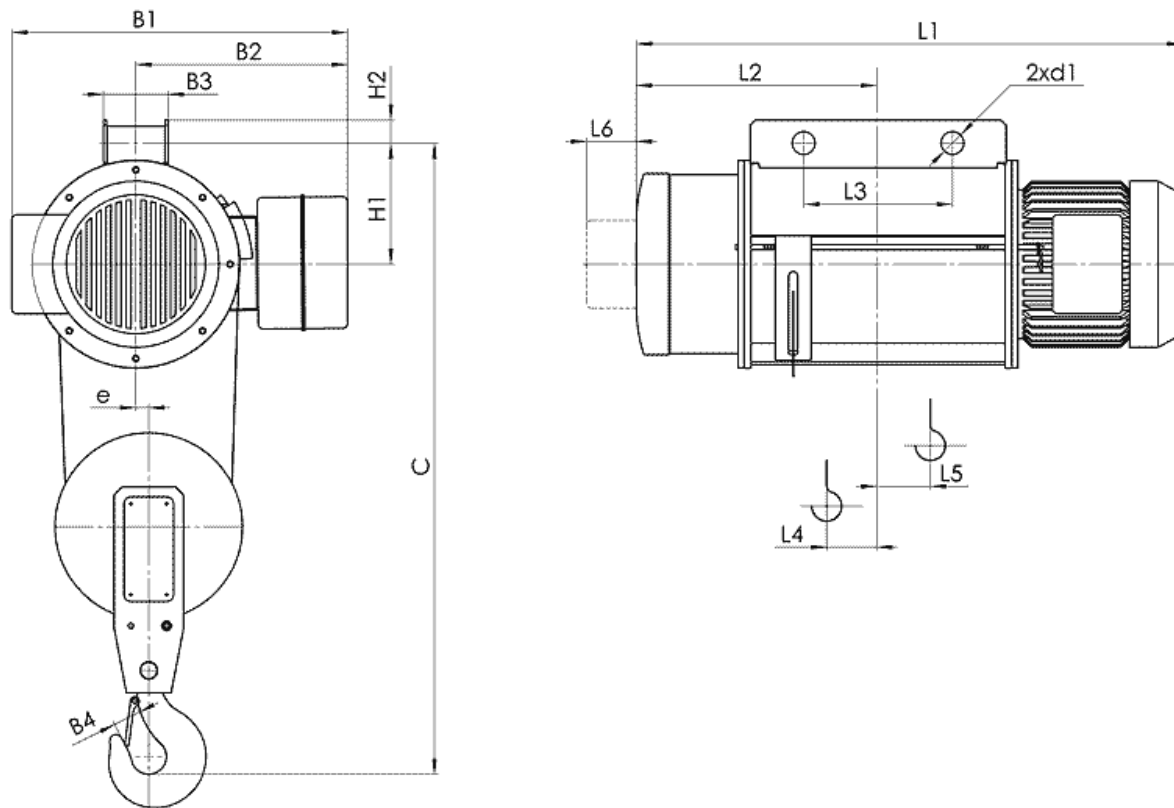

(1) с микроподъемом (2) с ограничителем груза (3) с ограничителем груза и с микроподъемом

Тип	Полиспаст 2/1		Размеры, мм																	
	Высота подъема, м	Грузоподъемность, кг	Скорость подъема m/min				L2	L3	L4	L5	L6	H1	H2	B1	B2	B3	B4	e	C	d1
			8	12	8/2	12/2														
			L1																	
T022...	H1	6	500	648	688	287	180	37	45	46	146	23	465 492 ⁽¹⁾ 557 ⁽³⁾	300 365 ⁽²⁾	88	34	18	790	25.5	
	H2	9		738	778	332	250	60	68											
	H3	12		818	858	373	80	88												
T023...	H1	6	1000	709	749	310	180	48	55	70	146	23	465 492 ⁽¹⁾ 557 ⁽³⁾	300 365 ⁽²⁾	88	40	18	850	25.5	
	H2	9		814	854	362	250	75	82											
	H3	12		914	954	412	100	106												
T024...	H1	6	2000	816	880	362	200	45	51	80	200	30	580 606 ⁽¹⁾ 668 ⁽³⁾	380 442 ⁽²⁾	118	45	22	1040	35.5	
	H2	9		926	990	417	270	73	79											
	H3	12		1026	1090	467	96	104												
T025...	H1	6	3200	856	923	377	200	52	59	80	200	30	580 606 ⁽¹⁾ 668 ⁽³⁾	380 442 ⁽²⁾	118	50	22	1120	35.5	
	H2	9		976	1043	437	270	82	89											
	H3	12		1086	1153	492	110	116												
T026...	H1	6	5000	905	993	395	225	49	66	90	242	46	675 682 ⁽¹⁾ 760 ⁽³⁾	430 508 ⁽²⁾	130	56	26	1300	46	
	H2	9		1010	1098	448	300	75	82											
	H3	12		1115	1203	500	101	108												

Тип	Полиспаст 2/1		Размеры, mm																
	Высота подъема, m	Грузопо- дъемность, kg	Скорость подъема m/min		L2	L3	L4	L5	L6	H1	H2	B1	B2	B3	B4	e	C	d1	
			16	16/2.5															
T022...	H4	18	500	1026	1090	467	270	97	106	80	200	30	580	380	118	45	22	890	35.5
	H5	24		1086	1153	492		97	131				606 ⁽¹⁾						
T023...	H4	18	1000	1086	1153	492		110	118				675	430				950	
													682 ⁽¹⁾	508 ⁽²⁾					
													760 ⁽³⁾						

Тип	Полиспаст 2/1		Скорость подъема, m/min				
	Высота подъема, m	Грузопо- дъемность, kg	8	12	8/2	12/2	
			Вес, kg				
T022...	H1	6	500	95	113		
	H2	9		100	118		
	H3	12		105	123		
T023...	H1	6	1000	107	130		
	H2	9		115	138		
	H3	12		124	147		
T024...	H1	6	2000	207	253		
	H2	9		222	268		
	H3	12		232	278		
T025...	H1	6	3200	240	250	305	
	H2	9		255	265	320	

	H3	12		270	280	335
T026...	H1	6	5000	360		455
	H2	9		380		475
	H3	12		400		495

Канатный электротельфер Т02 Стационарный, подвесной на пальцах, полиспаст 2/1

(1) с микроподъемом

(2) с ограничителем груза

(3) с ограничителем груза и с микроподъемом

Тип	Полиспаст 2/1		Размеры, mm																		
	Высота подъема, m	Грузоподъемность, kg	Скорость подъема m/min				L2	L3	L4	L5	L6	L7	H1	H2	B1	B2	B3	B4	e	C	d1
			8	12	8/2	12/2															
T022...	H4	18	500	978		452	490	55	192	40	46	138	18	465	300	88	34	18	780	16.5	
	H5	24		1138		532	650	55	272					492 ⁽¹⁾							365 ⁽²⁾
	H6	30		1226		567	610	89	214	60	80	185	25	580	380	128	34	22	870	20.5	
	H7	36		1306		602	680	110	228					606 ⁽¹⁾							442 ⁽²⁾
T023...	H4	18	1000	1114		512	610	75	231	40	70	138	18	465	300	88	40	18	845	16.5	
	H5	24		1314		612	810	149	332					492 ⁽¹⁾							365 ⁽²⁾
	H6	30		1426		667	810	90	312	60	80	185	25	675	430	128	40	22	930	20.5	
	H7	36		1526		712	900	110	338					682 ⁽¹⁾							508 ⁽²⁾
T024...	H4	18	2000	1226	1290	567	610	90	212	60	80	185	25			128	45	22	1025	20.5	

	H5	24		1426	1490	667	810	90	312					580 606 ⁽¹⁾ 668 ⁽³⁾	380 442 ⁽²⁾						
	H6	30		1535	1623	710	860	88	346	60	90	227	30	675 682 ⁽¹⁾ 760 ⁽³⁾	430 508 ⁽²⁾	144	45	26	1100	25.5	
	H7	36		1640	1728	762	965	75	398												
T025...	H4	18	3200	1306	1373	602	680	110	226	60	80	185	25	580 606 ⁽¹⁾ 668 ⁽³⁾	380 442 ⁽²⁾	128	50	22	1110	20.5	
	H5	24		1526	1593	712	900	110	336												
	H6	30		1640	1728	762	965	75	398	60	90	227	30	675 682 ⁽¹⁾ 760 ⁽³⁾	430 508 ⁽²⁾	144	50	26	1185	25.5	
	H7	36		1815	1903	850	1140	75	436												
T026...	H4	18	5000	1325	1413	605	650	124	193	60	90	227	30	675 682 ⁽¹⁾ 760 ⁽³⁾	430 508 ⁽²⁾	144	56	26	1275	25.5	
	H5	24		1535	1623	710	860	124	296												
	H6	30		1815	1903	850	1140	124	399												
	H7	36		1963	1969	905	1145	99	462	50	100	295	40	765 845 ⁽³⁾	470 550 ⁽²⁾	68	56	38	1390	25.5	
T027...	H2	9	8000	1133	1168	507	370	77	82	70	100	295	40	765 845 ⁽³⁾	470 550 ⁽²⁾	68	71	38	1580	41	
	H3	12		1293	1328	587	520	118	123												
	H4	18		1453	1488	667	680	78	242												
	H5	24		1668	1703	775	895	78	350												
	H6	30		1883	1918	882	1110	78	457												
	H7	36		2093	2128	987	1320	78	562												

Тип	Полиспаст 2/1			Размеры, mm																
	Высота подъема, m	Грузопо- дъемность, kg	Скорость подъема m/min		L2	L3	L4	L5	L6	L7	H1	H2	B1	B2	B3	B4	e	C	d1	
			16	16/2.5																
T022...	H6	30	500	1226	1290	567	610	89	214	60	80	185	25			128	34	22	870	20.5

	H7	35		1306	1373	602	680	110	228					580 606 ⁽¹⁾ 668 ⁽³⁾	380 442 ⁽²⁾					
T023...	H5	24	1000	1226	1290	567	610	90	212	60	80	185	25	675 682 ⁽¹⁾ 760 ⁽³⁾	430 508 ⁽²⁾	128	40	22	930	20.5
	H6	30		1426	1490	667	810	90	312											
	H7	36		1526	1590	712	900	110	338											
T024...	H5	24	2000	1325	1413	605	650	75	242	60	90	227	30	675 682 ⁽¹⁾ 760 ⁽³⁾	430 508 ⁽²⁾	144	45	26	1100	25.5
	H6	30		1535	1623	710	860	88	346											
	H7	36		1640	1728	762	965	75	398											
T025...	H4	18	3200	1325	1413	605	650	75	242	60	90	227	30	675 682 ⁽¹⁾ 760 ⁽³⁾	430 508 ⁽²⁾	144	50	26	1185	25.5
	H5	24		1535	1623	710	860	75	347											
	H6	30		1640	1728	762	965	75	398											
	H7	36		1815	1903	850	1140	75	436											
T026...	H4	18	5000	1488	1494	667	690	94	230	50	100	295	40	765 845 ⁽³⁾	470 550 ⁽²⁾	68	56	38	1390	25.5
	H5	24		1588	1594	717	790	94	280											
	H6	30		1778	1784	812	960	94	330											
	H7	36		1963	1969	905	1145	99	462											
T027...	H2	9	8000	1168	1174	507	370	77	82	70	100	295	40	765 845 ⁽³⁾	470 550 ⁽²⁾	68	71	38	1580	41
	H3	12		1328	1334	587	520	118	123											
	H4	18		1488	1494	667	680	78	242											
	H5	24		1703	1709	775	895	78	350											
	H6	30		1918	1924	882	1110	78	457											
	H7	36		2128	2134	987	1320	78	562											

Тип	Полиспаст 2/1		Скорость подъема, m/min					
	Высота подъема, m	Грузоподъемность, kg	8	12	8/2	12/2	16	16/2.5
			Вес, kg					
T022...	H4	18	500	119	137	226	272	
	H5	24		128	146	244	290	
	H6	30		250	297	251	297	
	H7	36		273	320	274	320	
T023...	H4	18	1000	137	160	247	293	
	H5	24		149	172	263	309	
	H6	30		286	333	287	333	
	H7	36		306	353	307	353	
T024...	H4	18	2000	267	313	466	486	
	H5	24		292	338	486	541	
	H6	30		526	581	526	581	
	H7	36		546	601	546	601	
T025...	H4	18	3200	310	320	375	490	545
	H5	24		340	350	405	535	590
	H6	30		525	565	620	565	620
	H7	36		550	590	645	590	645
T026...	H4	18	5000	460	555	818	823	
	H5	24		510	605	838	843	
	H6	30		570	665	860	865	
	H7	36		840	900	900	905	

T027...	H2	9	8000	660	720	720	725
	H3	12		700	760	760	765
	H4	18		765	825	825	830
	H5	24		825	885	885	890
	H6	30		880	940	940	945
	H7	36		940	1000	1000	1005